

VICTORY[®]

INSTALLATION AND OPERATING INSTRUCTIONS for all Hydrocarbon FS and FSA Freezer Models



809-191A Rev E. 02/05/2026

3779 CHAMPION BLVD, WINSTON-SALEM, NC 27105

Phone: (888) 845-9800 | Fax: (800) 253-5168 | Web: victoryrefrigeration.com

**SEE BACK COVER FOR
WARRANTY REGISTRATION**



WELCOME

Thank you for purchasing a Victory cabinet. This series has passed our strict quality control inspection and meets the high standards set by Victory! You have made a quality investment that with proper maintenance will give you many years of reliable service!

Please read the following installation and maintenance instructions before installing or using your unit.

Important Information

- PLEASE READ THESE INSTRUCTIONS CAREFULLY BEFORE INSTALLING OR USING, IF RECOMMENDED PROCEDURES ARE NOT FOLLOWED, WARRANTY CLAIMS MAY BE DENIED.
Your warranty registration information is located with this manual. Please complete the card and submit it to Victory within TEN days of installation. Failure to properly register equipment may limit or void the warranty.
Victory reserves the right to change specifications and product design without notice. Such revisions do not entitle the buyer to corresponding changes, improvements, additions, or replacements for previously purchased equipment.

Safety 3
Important Information 5
Product Information 6
Clearance and Placement 8
Unpacking and Set Up 9
Shelf Installation.....10
Electrical..... 11
Using The Unit12
Sequence of Operations Freezer13
Control Panel Display14
Electronic Controller Parameter Changes16
Setting the Real Time Clock17
Cleaning and Maintenance20
Condenser Cleaning.....21
Methods For Cleaning Stainless Steel.....22
Help.....23
For The Service Tech - R29024
For The Service Tech - Single System Wiring Diagram.....25
For The Service Tech - TWO System Wiring Diagram.....26
Limited Warranty27
Limited Warranty (continued).....28

SAFETY

This appliance has been designed with your safety in mind. It has many features to keep you from being harmed. However, safe operation and maintenance are your responsibilities.



Use: When using this unit, please:

- **Move it carefully.** If on casters be sure the casters do NOT run over the power cord.
- **Lock** the casters when in use.
- **Seek help.** This machine is heavy! Be sure to move with enough help to avoid tipping or dropping the cabinet.
- **Prevent children from playing in or on the cabinet.** Persons unable to use this product must be prevented access.
- **Follow all instructions.** There are many safety labels and directions on the unit. Heed them.
- **Watch your fingers.** There may be pinch points near the door hinges.



Maintenance

Do NOT:

- Clean a frozen evaporator with a sharp object
- Clean a dirty condenser with a sharp object.
- Store gasoline, kerosene or any other flammable material near the cabinet.

Do ALWAYS

- Use a Victory recommended technician certified to repair R290 equipment.
- Use **ONLY** Victory factory service parts. Use of non OEM parts can be dangerous because of the design changes needed to safely use R290.

Important Information to Add

Record the model number, serial number and the date of installation here for future reference. The model and serial numbers are on the unit's serial number dataplate, which is located on the left inside wall.

Model Number	
Serial Number	
Date of Installation	
Purchased From	



Observe the **Caution** and **Warning** notices. They are indicators of important safety information. Keep this manual for future reference.

SAFETY



CAUTION: If it is necessary to move the Freezer after removal from the skid, remove all doors and carefully push the unit at a point of no more than 36" from the bottom to avoid damage.



IMPORTANT INFORMATION

This unit is intended to be used in a commercial application. That includes bars and restaurants.

If installed in a residence some commercial service companies may not be able to service it on site.

The manufacturer has designed and produced this machine with the finest in materials. The manufacturer assumes no liability for units that have been altered in any way. Alterations or part substitutions will void the warranty.

Limitations

The machine is designed for use indoors in a controlled environment. It must be kept dry, not overheated or subjected to excessive cold. May only be connected to a dedicated electrical circuit. Extension cords are not permitted.

	Minimum	Maximum
Voltage	103.5	126.5
Room Air Temp	60° F	100° F

Air Flow, All Models regardless of section, door count or door material.

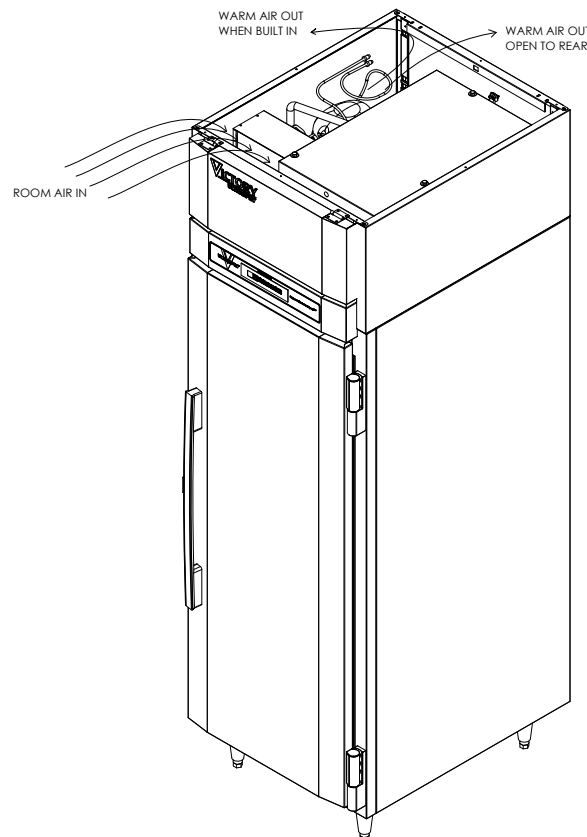

Agency Approvals

These marks appear on the dataplate or serial tag, located in the inside of the left wall. The dataplate also contains the model and serial numbers as well as electrical requirements.



PRODUCT INFORMATION

Model	Cabinet Dimensions w x d x h (Inches)	Sections	Half or Full Door	Glass or Solid Door	Full Load Amps	Refrigerant Type / Charge (g) / Charge (oz.)
FS(A)-1D-S1-HC	26 1/2 x 34 7/8 x 84 1/8	1	Full	Solid	9.1	R-290 / 130 / 4.59
FS(A)-1D-S1-HD-HC	26 1/2 x 34 7/8 x 84 1/8		Half	Solid		
FS(A)-1D-S1-G-HC	26 1/2 x 33 1/2 x 84 1/8		Full	Glass		
FS(A)-1D-S1-HG-HC	26 1/2 x 34 1/4 x 84 1/8		Half	Glass		
FS(A)-1D-S1-EW-HC	31 1/4 x 34 7/8 x 84 1/8		Full	Solid		
FS(A)-1D-S1-EW-HD-HC	31 1/4 x 34 7/8 x 84 1/8		Half	Solid		
FS(A)-1D-S1-EW-G-HC	31 1/4 x 33 1/2 x 84 1/8		Full	Glass		
FS(A)-1D-S1-EW-HG-HC	31 1/4 x 33 5/8 x 84 1/8		Half	Glass		
FS(A)-1N-S1-HC	31 1/4 x 30 3/8 x 84 1/4		Full	Solid		
FS(A)-1N-S1-HD-HC	31 1/4 x 30 3/8 x 84 1/8		Half	Solid		
FS(A)-1N-S1-G-HC	31 1/4 x 29 x 84 1/8		Full	Glass		
FS(A)-1N-S1-HG-HC	31 1/4 x 29 x 84 1/8		Half	Glass		
FS(A)-1D-S1-PT-HC	26 1/2 x 38 3/4 x 84 1/8		Full	Solid		
FS(A)-1D-S1-PT-HD-HC	26 1/2 x 38 3/4 x 84 1/8		Half	Solid		
FS(A)-1D-S1-PT-G-HC	26 1/2 x 38 3/4 x 84 1/8		Full	Glass		
FS(A)-1D-S1-PT-HG-HC	26 1/2 x 36 1/8 x 84 1/8		Half	Glass		
FS(A)-1D-S1-EW-PT-HC	31 1/4 x 38 5/8 x 84 1/8		Full	Solid		
FS(A)-1D-S1-EW-PT-HD-HC	31 1/4 x 38 5/8 x 84 1/8		Half	Solid		
FS(A)-1D-S1-EW-PT-G-HC	31 1/4 x 35 3/4 x 84 1/8		Full	Glass		
FS(A)-1D-S1-EW-PT-HG-HC	31 1/4 x 36 1/8 x 84 1/8		Half	Glass		
FS(A)-2D-S1-HC	52 1/8 x 34 7/8 x 84 1/8	2	Full	Solid	10.5	R-290 / 130 / 4.59
FS(A)-2D-S1-HD-HC	52 1/8 x 34 7/8 x 84 1/4		Half	Solid	13.9	
FS(A)-2D-S1-G-HC*	52 1/8 x 33 1/2 x 84 1/4		Full	Glass		
FS(A)-2D-S1-HG-HC*	52 1/8 x 33 1/2 x 84 1/4		Half	Glass	10.5	
FS(A)-2D-S1-EW-HC	58 3/8 x 34 7/8 x 84 1/8		Full	Solid		
FS(A)-2D-S1-EW-HD-HC	58 3/8 x 34 7/8 x 84 1/8		Half	Solid	13.9	
FS(A)-2D-S1-EW-G-HC*	58 3/8 x 33 1/2 x 84 1/8		Full	Glass		
FS(A)-2D-S1-EW-HG-HC*	58 3/8 x 33 1/2 x 84 1/8		Half	Glass	10.5	
FS(A)-2N-S1-HC	58 3/8 x 30 1/4 x 84 1/8		Full	Solid		
FS(A)-2N-S1-HD-HC	58 3/8 x 30 1/4 x 84 1/8		Half	Solid	13.9	
FS(A)-2N-S1-G-HC*	58 2/5 x 28 7/10 x 84 1/5		Full	Glass		
FS(A)-2N-S1-HG-HC*	58 2/5 x 28 9/10 x 84 1/5		Half	Glass		

Model	Cabinet Dimensions w x d x h (Inches)	Sections	Half or Full Door	Glass or Solid Door	Full Load Amps	Refrigerant Type / Charge (g) / Charge (oz.)
FS(A)-2D-S1-PT-HC*	52 1/8 x 38 5/8 x 84 1/8	2	Full	Solid	13.9	R-290 / 130 / 4.59
FS(A)-2D-S1-PT-HD-HC*	52 1/8 x 38 5/8 x 84 1/8		Half	Solid		
FS(A)-2D-S1-PT-G-HC*	52 1/8 x 35 3/4 x 84 1/8		Full	Glass		
FS(A)-2D-S1-PT-HG-HC*	52 1/8 x 36 x 84 1/8		Half	Glass	9.1	
FS(A)-2D-S1-EW-PT-HC*	58 3/8 x 38 3/4 x 84 1/8		Full	Solid	13.9	
FS(A)-2D-S1-EW-PT-HD-HC*	58 3/8 x 38 3/4 x 84 1/8		Half	Solid		
FS(A)-2D-S1-EW-PT-G-HC*	58 3/8 x 35 7/8 x 84 1/8		Full	Glass		
FS(A)-2D-S1-EW-PT-HG-HC*	58 3/8 x 36 1/8 x 84 1/8		Half	Glass		
FS(A)-3D-S1-HC*	77 3/4 x 34 7/8 x 84 1/4	3	Full	Solid		
FS(A)-3D-S1-HD-HC*	73 3/4 x 34 7/8 x 84 1/4		Half	Solid		
FS(A)-3D-S1-G-HC*	77 3/4 x 33 1/2 x 84 1/4		Full	Glass		
FS(A)-3D-S1-HG-HC*	77 3/4 x 33 5/8 x 84 1/4		Half	Glass		
FS(A)-3D-S1-EW-HC*	85 1/2 x 34 7/8 x 84 1/8		Full	Solid		
FS(A)-3D-S1-EW-HD-HC*	85 1/2 x 34 7/8 x 84 1/8		Half	Solid		
FS(A)-3D-S1-EW-G-HC*	85 1/2 x 33 3/8 x 84 1/8		Full	Glass		
FS(A)-3D-S1-EW-HG-HC*	85 1/2 x 33 1/2 x 84 1/8		Half	Glass		

Height includes casters.

- FS models have stainless steel liners; FSA models have aluminum liners.
- * These models have two refrigeration systems, charge numbers are for each system.
- Freezer Capable Of Maintaining Product Temperature 0°F and below.
- All models are 115 volts, 60 Hz AC, and are equipped with a NEMA 5-15P or 5-20P plug, depending upon model.
- ALWAYS REFERENCE YOUR EQUIPMENT DATA PLATE AMPS, REFRIGERANT AND REFRIGERANT CHARGE FOR THE MOST UP TO DATE AND ACCURATE VALUES.
- There are no access valves on the refrigeration system.
- Ultra Glass doors are optional - for full Ultra Glass Doors change G to UG, for Ultra Glass half doors, change HG to HD-UG.

CLEARANCE AND PLACEMENT

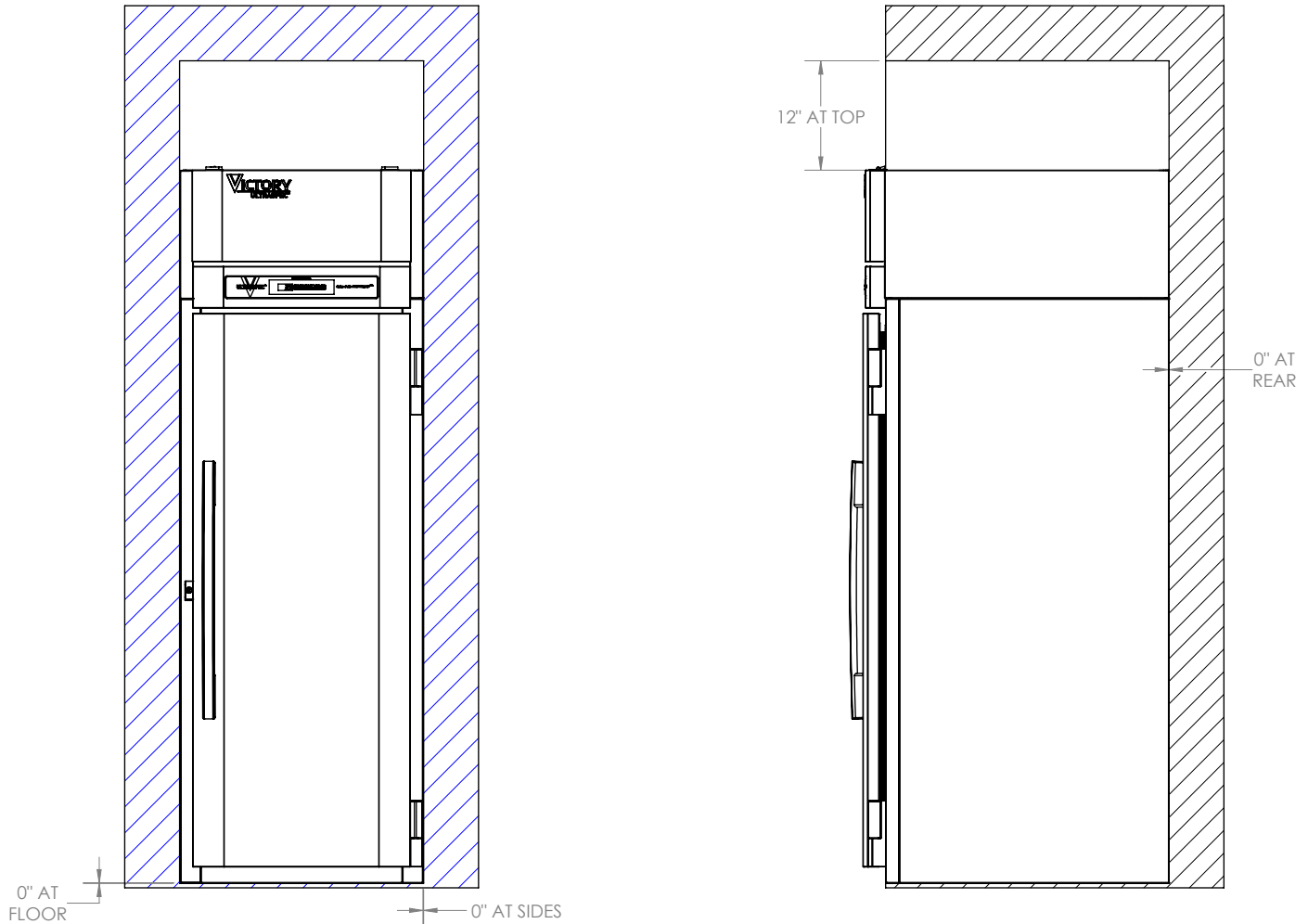

Placement

Consider the following when selecting a location for your Freezer:

Clearance:

- 12 in. at the top
- 0.0 in. at the rear,
- 0.0 in. at the left side
- 0.0 in. at the right side

Floor Load: the floor on which the Freezer is located must be even and level, free from vibrations, and strong enough to support the combined weights of the unit and maximum product load.

Ventilation: Grille area at front must be free and clear of any object or wall.

Power Outlet: Dedicated power outlet is located within the length of the unit's power cord.

UNPACKING AND SET UP

Carefully inspect the shipping carton for damage. This is the only time that shipping damage may be claimed. If damage is suspected, open the carton immediately and, if there is damage, retain the carton and contact the shipper to make a claim. Do NOT contact the manufacturer.

Uncrating

Tools Needed: 3/4" box wrench, adjustable wrench, level, flat head screw driver, and box cutter.

1. Remove the cardboard top capping, all clear tape, and all staples including those at the bottom of the cardboard carton and skid.
2. Start from the top of the carton. Using the box cutter, carefully make one continuous cut to the bottom of the skid. Remove cardboard carton and discard.

3. Move unit as close to final position as possible before removing the skid.

Note: The skid must be removed before the casters or legs can be attached.

Do NOT tip unit on its front or sides. If tipped onto the back, unit must not be started for 3 hours.

Note: additional clear plastic protective wrap is applied directly to any product with a glass door.

Skid Removal and Caster Attachment

Tip the unit forward and remove the skid.



1. Remove the shipping bolts using the 3/4" box wrench while cabinet is held in one direction. Repeat the process while the cabinet is held in the opposite direction.
2. Tilt the cabinet in one direction approximately 8" and block it securely with pieces of 2x4 lumber or other suitable material.

Note for the following: None of the threads on the leg or caster stem should be visible once screwed in.

3. Thread the stem casters or legs into the 1/2"-13 holes in the bottom of the cabinet. Tighten by hand as much as possible. Some models may already have levelers installed. If so, then the levelers will need to first be removed and discarded.
4. Once the caster or leg cannot be turned any further, use a 3/4 inch wrench to tighten the nut in between the mounting plate and the wheel of the caster until snug.
5. Repeat this procedure with unit secured in the opposite direction so as to access the remaining legs/casters/levelers
6. If plate casters or legs are installed instead of stem casters or legs, then repeat step 3 above and secure the plate with either #14 AB screws, or 1/4"-20 screws, depending upon which are required.
7. If levelers are employed, then repeat step 3 above and thread the leveler in place. Then repeat step 5.

Leveling

Cabinets must be leveled when installed. Level should be measured on the headrail.

Failure to level your cabinet may result in door not sealing, closing correctly, or condensed water not draining properly.

For cabinets with legs, rotate the foot of the leg with an adjustable wrench to achieve desired height for leveling.

For cabinets with casters, level by placing large washers in between the 1/2" stud and the holes in the bottom of the case.



Do NOT loosen casters to level the cabinet. Casters MUST be tightly secured to cabinet for full strength.

Install or attach any accessories that will be used Remove any plastic covering the stainless steel.

SHELF INSTALLATION

1. Determine the proper location for the shelf clips.
2. Insert the top tab of the shelf clip into the desired hole of the pilaster. The retaining tab **MUST** be facing up as shown.
3. Rotate the clip downwards and insert the bottom tab into the matching hole in the pilaster. The clip may need to be squeezed slightly during installation.
4. Install all remaining clips.
5. Install shelves onto clips with the product retention bar facing up. Be careful not to dislodge clips during installation.
6. Place shelves so that the retaining tab on the clip captures the shelf as shown.
7. Confirm that the shelf is resting on ALL 4 clips and that the clips are securely attached to the pilasters.
8. Improper shelf clip installation could cause the shelf and / or the product on it to fall, resulting in damage to the unit and possible bodily injury.
9. Do NOT overload the shelves. The unit is designed to use all shelves that are supplied in an equally spaced manner. Contact Victory customer service if fewer shelves or a different configuration to ensure shelf overloading will not occur.

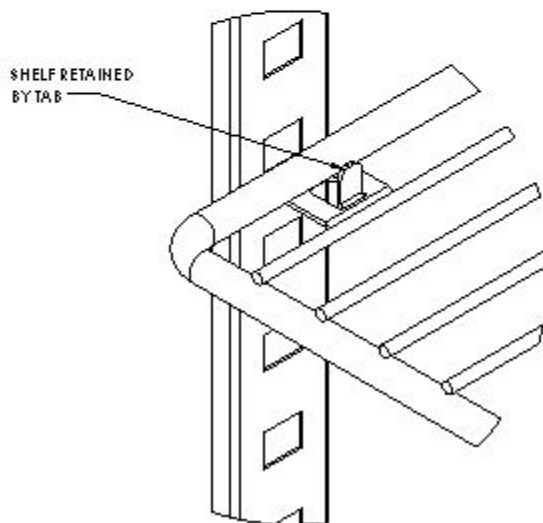
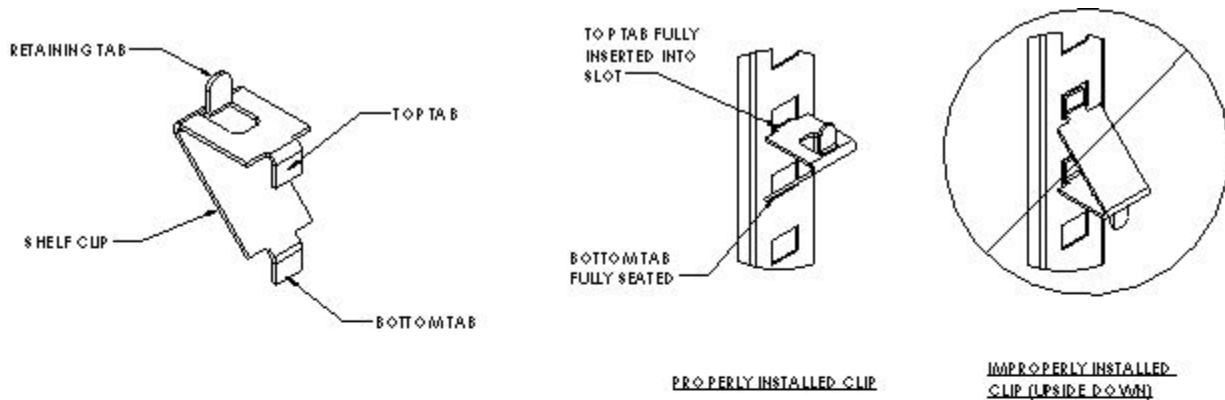

ELECTRICAL

This is a cord-connected unit, and must be connected to its own **dedicated** power supply. Check the dataplate on the machine to confirm the voltage and per the dataplate use the correct fuses or HACR circuit breakers.

Power Cord

This 115 volt model is equipped with a cord and either a 5-15P or 5-20P plug.

If the power cord becomes damaged, it must be replaced with the identical cord.

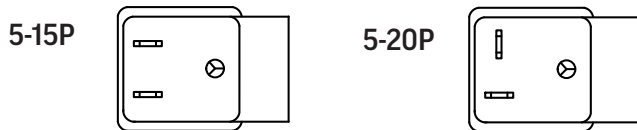

GFCI

Units that utilize variable speed compressor technology can experience nuisance tripping on Class A GFCI outlets which have a trip limit of 4 to 6 mA. To avoid this issue in a location that requires GFCI circuit protection, Victory recommends using either an Eaton, SGF20, or HUBBELL Model Number GFRST83W 20A Heavy Duty Hospital Grade Self-Test GFCI Receptacle.

Follow All National and Local Codes

This unit must be grounded. Do not use extension cords and do not disable or by-pass ground prong on electrical plug.

Initial Start Up

Plug the power cord into the proper power supply.

The cabinet will soon begin to blow warm air out of the top area, and cool air will flow from the inside blower.

The cabinet temperature has been set at the factory and should not need adjustment, however if it was changed, the standard setting is 0° F.

Cautions

Care must be taken whenever moving or servicing the unit. The refrigerant is contained in a sealed system, but if released it may be flammable.

After the cabinet has been installed, leveled, and cleaned as described above, refer to the following checklist:

- Check for proper electrical hook-up.
- Cabinet **MUST NOT SHARE A RECEPTACLE** with another piece of equipment
- Check that all clearances are in line with the aforementioned guidelines.
- Check that cabinet is level.

* NOTE: Once the unit has been started and reaches proper storage temperatures, it may be loaded with product. For proper energy efficiency and airflow we recommend a minimum 1" clearance between product and side walls, 4" clearance between product and ceiling, and 1" clearance from the bottom of the unit.

USING THE UNIT

Operation is simple, just keep it connected to the correct power supply and the Freezer will maintain the internal temperature it has been set to. Keep the doors closed as much as possible to avoid unnecessary run time.

The controller displays the current internal temperature.

Adjusting the set temperature lower will NOT cause the system to lower the temperature faster. When on, the refrigeration system is always operating at maximum.

The temperature was set at the factory at 0° F, but you can adjust it to your own selected temperature. See page 15.



The Freezer will automatically defrost as needed, there is no set time for defrost. Push and immediately release the "melting" or defrost button for a manual defrost.

The internal fan will be on when the compressor is on and when the doors are closed.

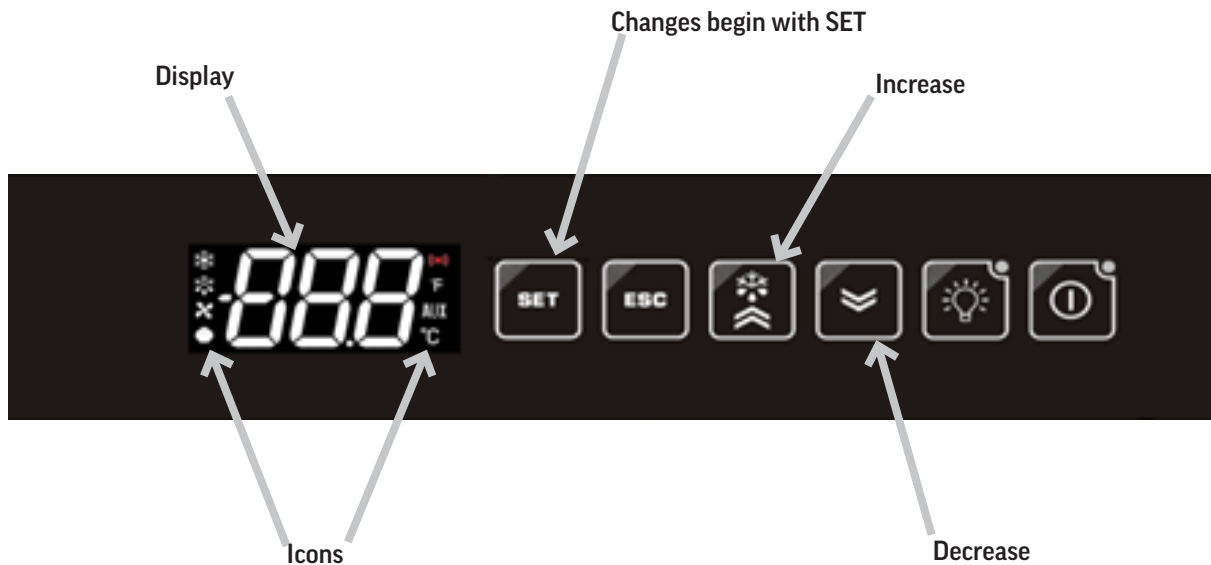
The compressor and condenser fan motor will only be on when the controller senses an increase in internal cabinet temperature passed the set point.



SEQUENCE OF OPERATIONS



	ON		OFF	
COMPONENT	OPERATION	CONTROLLER ACTION	OPERATION	CONTROLLER ACTION
COMPRESSOR	Compressor turns on when the cabinet temperature is above the sum of the set point and the dead band	The Compressor Contact is energized	Compressor turns off when the cabinet temperature is equal to or less than the set point	The Compressor Contact is de-energized
		RTN400 terminals 10, 11		RTN400 terminals 10, 11
CONDENSER FAN	The Condenser Fan turns on when the Compressor is running	The Condenser Fan is wired directly to the Compressor, not through the controller	The Condenser Fan turns off when the Compressor is not running	The Condenser Fan is wired directly to the Compressor, not through the controller
EVAPORATOR FAN	The Evaporator Fan runs when the evaporator temperature is below 35°F and the door is closed	The Evaporator Fan is connected to control relay.	The Evaporator Fan is off when the evaporator temperature is above 35°F or the door is opened	The Evaporator Fan is connected to control relay.
		RTN400 terminals 4, 5		RTN400 terminals 4, 5
DEFROST HEATER	The Defrost Heater is on at least once every 8 hours or if the evaporator is -35°F or below	The Defrost Heater Contact is energized	When either the defrost is not scheduled or the coil has reached the defrost termination temperature (37°F)	The Defrost Heater Contact is de-energized
		RTN400 terminals 7, 9		RTN400 terminals 7, 9
FACE/DOOR HEATERS	The Face/Door Heaters turn on when the Compressor is running	The Compressor Contact is energized	The Face/Door Heaters turn off when the Compressor is not running	The Face/Door Heater are wired to the Compressor Contact
		RTN400 terminals 10, 11		RTN400 terminals 10, 11
LIGHT	The light will turn on when the door is open (solid door models only) or light button is pressed 	The Light Contact is energized	The light will turn off when the door is closed (solid door models only) or the light button is pressed 	The Light Contact is de-energized
		RTN400 terminals 13,14		RTN400 terminals 13,14
DRAIN TUBE HEATER	The drain tube heater is always on	Wired to direct power, not through the control	The Face & Door Heaters run continuously	Wired to direct power, not through the control

Condition	Compressor	Condenser Fan	Evaporator Fan	Defrost Heater	Face/Door Heater	Drain	Lights
Cabinet Temp > Set point + Dead band	ON	ON	ON	OFF	ON	ON	ON or OFF
Cabinet Temperature <= Set point	OFF	OFF	ON	OFF	OFF	ON	ON or OFF
Defrost	OFF	OFF	OFF	ON	OFF	ON	ON or OFF

CONTROL PANEL DISPLAY







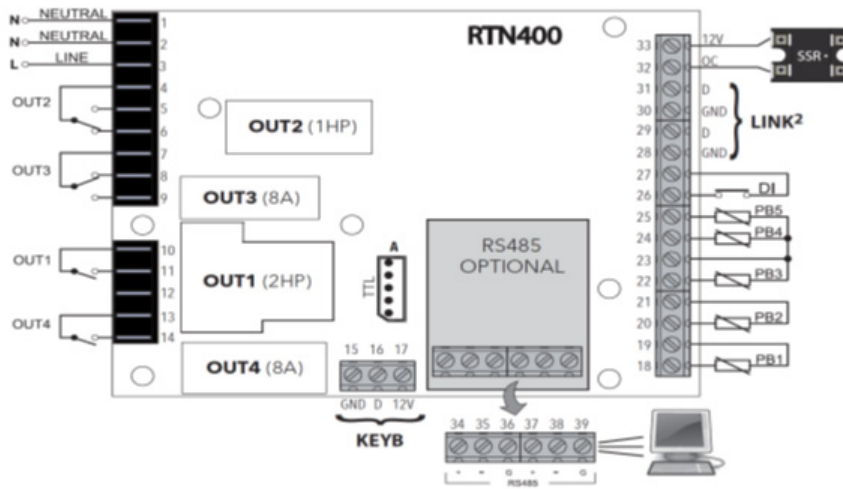

Control Panel Indicators

No	Icon	LED	Operation	Meaning
1		Compressor	Permanently On	Compressor On
			Blinking	Delay, protection or start-up blocked
			OFF	Otherwise
2		Defrost	Permanently On	Defrost active
			Blinking	Activated manually or from Digital input
			OFF	Otherwise
3		Fans	Permanently On	Fans active
			OFF	Otherwise
4		Reduced SET / Economy	Permanently On	Energy saving active
			Blinking	Reduced setpoint active
			OFF	Otherwise
5		Alarm	Permanently On	Alarm active
			Blinking	Alarm acknowledged
			OFF	Otherwise
6		°F readout	Permanently On	°F setting (dro = 1)
			OFF	Otherwise
7		AUX	Permanently On	Aux output active and/or light on
			Blinking	Deep cooling on
			OFF	Otherwise
8		°C readout	Permanently On	°C setting (dro = 0)
			OFF	Otherwise

NOTE: When switched on, the instrument panel performs a lamp test and for a few seconds, the display and LEDs flash to verify their condition and proper operation.



Relay/Probe	Description	Terminal
Out 1	Compressor	10,11
Out 2	Evaporator Fan	4, 5
Out 3	Defrost Element	7, 9
Out 4	Light (or alarm relay if electronic Lock model)	13, 14
PB1 –	Air/control probe	18, 19
PB2	Evaporator/defrost probe	20, 21
PB3	Evaporator 2 probe	22, 23
PB4&5	not used	
DI	digital input/Door switch	26, 27
KEYB	Display connection	15, 16, 17

LIGHT	STANDBY	UP	DOWN	ESC	SET (Enter)
Press and Hold	Press and Hold	Press and Release	Press and Release	Press and Release	Press and Release
Long press (>5 sec) Toggles light on and off. If LED is on, light is activated	Places unit in Standby Mode. If LED is on. Device is off.	Scrolls the menu items Increases the values. Long press (>5 sec) starts manual defrost	Scrolls the menu items Decreases the values. Long press (> 5 sec) Starts deep cooling cycle	Returns up one level with respect to the current menu. Confirms the parameter value	Accesses the machine status menu and displays any alarms (if present)
					

ELECTRONIC CONTROLLER PARAMETER CHANGES

Note: Key pad has a 3 second lock feature. Set key must be pressed for 3 seconds and released before keys will become active. Key pad will beep when unlocked and normal key pad operations performed.

Setting the Operating Set Point

To change the operating set point, press and release the set button to enter the machine menu. “set” will appear on the display.



Press and release the set button again to view the set point.



Use the up and down button to change the set point. When adjustment is finished, use the escape button to exit out of the machine status menu.

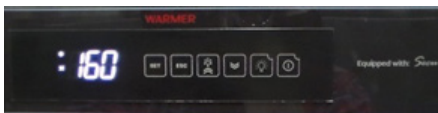

SETTING THE REAL TIME CLOCK

To set the real time clock, press and release the set button to enter the machine status menu. "Set" will appear on the menu.



Use the up and down button to scroll to the real time clock menu folder. "Rtc" will appear on the display.



Press the set button to enter into the clock setup menu. "Day" will appear on the display. Use the up and down buttons to scroll to the hour (h), minute (') or day (day) that needs to be changed.



Press the set button to display the value and use the up or down button to change the value. Once the value has been selected, use the escape button to confirm the new value and return the previous menu level. Repeat the previous steps to change the remaining parameters.

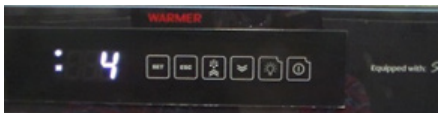

Viewing Alarm Codes

To view the alarm codes, press the set button to enter the machine status menu. "Set" will appear on the display.



Use the up and down button to scroll the alarm folder in the menu. ALr will appear on the display.

Press the set button to enter into the list of active alarms. Use the up and down button to scroll thru the alarms. Once alarm codes have been viewed, use the escape button to exit out the menu and view set point.



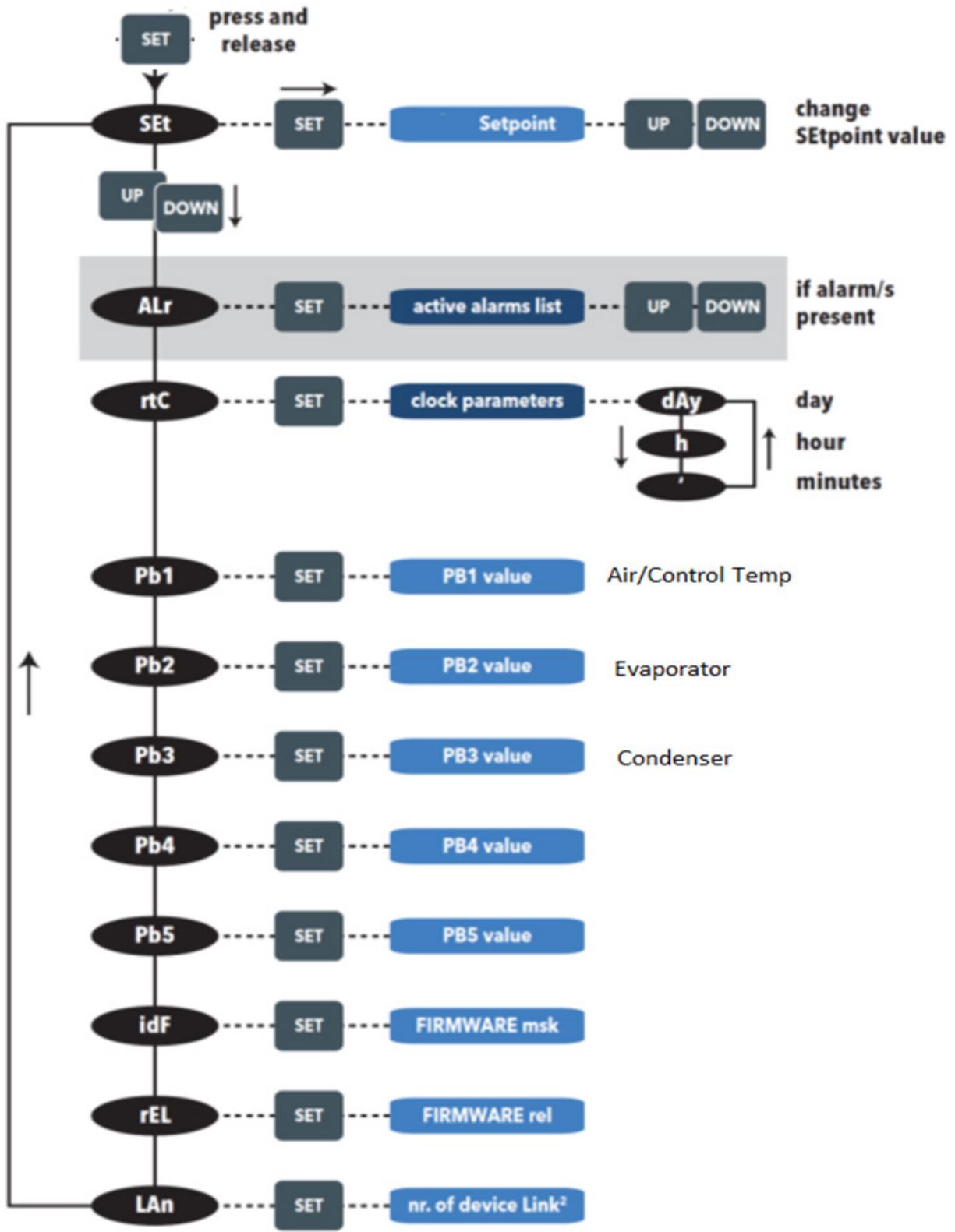

Code Description	Description	LED	Relay	Reset	Parameters involved to Enable alarm
E1	Probe Pb1 failure	ON	Active	Automatic	Ont, Oft
E2	Probe Pb2 failure	ON	Active	Automatic	Ont, Oft
E3	Probe Pb3 failure	ON	Active	Automatic	Ont, Oft
E4	Probe Pb4 failure	ON	Active	Automatic	Ont, Oft
E5	Probe Pb5 failure	ON	Active	Automatic	Ont, Oft
EL	LINK2 probe failure	ON	Active	Automatic	Ont, Oft
Ei	Virtual probe failure	ON	Active	Automatic	Ont, Oft
AH1	HIGH temperature 1 alarm	ON	Active	Automatic	SP1, Att,Afd,HA1,PAO,dAO,OAO,tA1
AL1	LOW temperature 1 alarm	ON	Active	Automatic	SP1, Att,Afd,HA1,PAO,dAO,OAO,tA1
AH2	HIGH temperature 2 alarm	ON	Active	Automatic	SP2, Att,Afd,HA2,PAO,dAO,OAO,tA2
AL2	LOW temperature 2 alarm	ON	Active	Automatic	SP2, Att,Afd,HA2,PAO,dAO,OAO,tA2
EA	External alarm	ON	Active	Automatic	PEA, EAL
OPd	Door open alarm	ON	not active	Automatic	PEA, tdO
Ad2	End of defrost due to time-out	ON	not active	Automatic	dE1, dE2, dAt
Prr	Preheating alarm	ON	not active	Automatic	
E10	Clock alarm	ON	not active	Automatic	
HiP	HIGH voltage alarm	ON	not active	Automatic	SPH, SPL, dFL, SoU
LoP	LOW voltage alarm	ON	not active	Automatic	SPH, SPL, dFL, SoU
nPA	General pressure switch alarm	ON	not active	Automatic	PEn, PEi
LPA	High pressure switch alarm	ON	not active	Automatic	PEn, PEi
HPA	Low pressure switch alarm	ON	not active	Automatic	PEn, PEi
PA	General pressure switch alarm	ON	not active	Manual	PEn, PEi

CLEANING AND MAINTENANCE

Cleaning Schedule:

Cabinet	Condenser coil	Gaskets	Routine maintenance
Daily wipe down	Monthly inspection, cleaning as required	Daily inspection, check that hinges are tight to the cabinet.	Annually
Weekly interior			

Daily Exterior Cleaning

It is much easier to clean on a regular basis than to have to remove stains once they have built up.

1. Wash with a clean sponge and a mild detergent that does not contain chlorine.
2. Rinse with clean water.
3. Dry with a soft cloth.
4. Polish with a soft cloth, wiping with the grain.
5. Wipe weekly with stainless steel cleaner.

Weekly Interior Cleaning

1. Remove all food, food related items and shelves. Store the food at a safe temperature.
2. Disconnect power to the unit (unplug it or switch the breaker off).
3. Remove all loose food particles from the inside walls, floor, door liner and ceiling.
4. Scrub all interior surfaces and door gaskets with a warm (100°F to 110°F) detergent solution and a soft scrub brush.
5. Rinse with clean water and allow to air dry.
6. Return the shelves to the unit and secure them.
7. Restore power.
8. Return food to the unit when it has reached a safe temperature.

CONDENSER CLEANING

Keeping the condenser coil clean is critical to efficient operation.

1. Unplug unit from power supply.



CAUTION

Rotating fan blade can cause personal injury.

Unplug unit from power supply before beginning to clean condenser

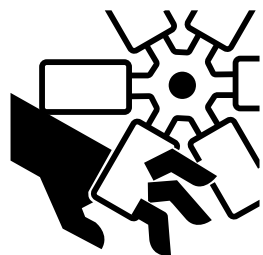

2. Pull out on the bottom of the top panel to disengage the locking clips
3. Raise the hinged panel

4. Remove the panel stand from its clip and secure into the notch in the front right corner of the raised panel
5. Examine condenser surface, if dusty, brush and vacuum the dust and lint from the surface of the coil. Brush up and down to avoid damaging the fins. Use care to not disturb the wires connected to the controller.

Note: If the coil is greasy, the coil will need to be cleaned with coil cleaner and that should be left to an experienced technician.

6. To close, replace stand in its rest and lower panel to the close position. Push firmly on the bottom to engage locking clips

Note: Air filters are not recommended as they restrict the flow of cooling air.

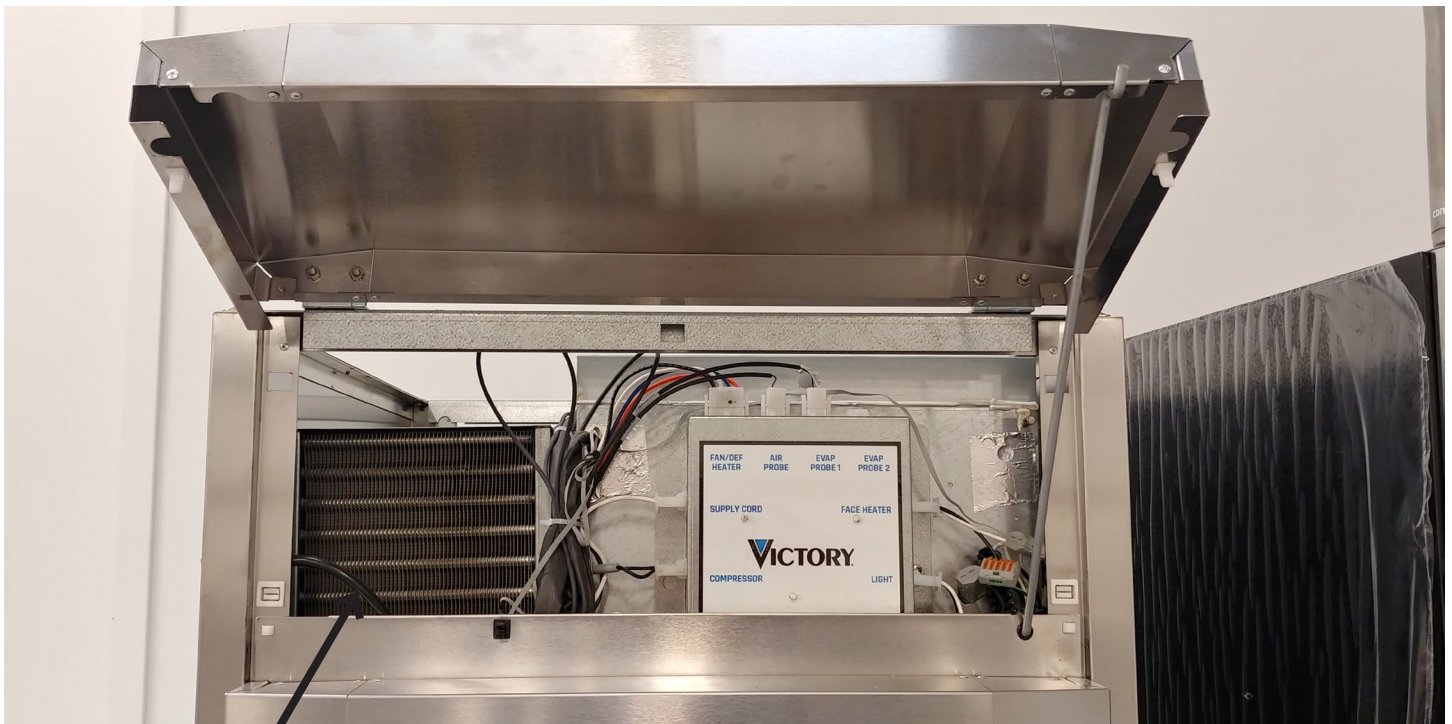

Condenser Surface

METHODS FOR CLEANING STAINLESS STEEL

Cleaning Needed	Cleaning Agent	Method of Application	Affect on Finish
Smears and fingerprints	Areal 20, Lac-O-Nu, Lumin Wash O’Cedar Cream Polish, Stainless Shine.	Rub with cloth as directed on the package.	Satisfactory for use on all finishes. Provides barrier film to minimize prints.
Stubborn Spots and Stains, Baked-On Splatter, and Other Light Discolorations	Allchem Concentrated Cleaner.	Apply with damp sponge or cloth. Rub with damp cloth.	Use in direction of polish lines on No. 4 (polished) finish. May scratch No. 2 (mill) and Nos. 7 and 8 (polished) finishes.
	Samae, Twinkle or Cameo Copper Cleaner	Rub with damp cloth.	
	Grade FFF Italian pumice, whiting, or talc.	Rub with dry cloth.	
	Liquid NuSteel Paste NuSteel or DuBois Temp. Copper’s Stainless Steel Cleaner Revere Stainless Cleaner Household cleansers, such as Old Dutch, Lighthouse, Sunbrite, Wyandotte, Bab-O, Gold Dust, Sapolio, Bon Ami, Ajax, or Comet Grade F Italian Pumice, Steel Bright, Lumin Cleaner, Zud, Restore, Sta-Clean, or Highlite. Penny-Brite or Copper-Brite.	Use small amount of cleaner. Rub with dry cloth using a small amount of cleaner. Apply with damp sponge or cloth. Rub with a damp cloth. May contain chlorine bleaches. Rinse thoroughly after use. Rub with a damp cloth. Rub with a dry cloth using a small amount of cleaner.	
Heat tint or discoloration	Penny-Brite or Copper-Brite. Past NuSteel, DuBois Temp, or Tarnite. Revere Stainless Steel Cleaner. Allen Polish, Steel Bright, Tenacious Deposits, Rusty Discolorations, Industrial Atmospheric Stains Wyandotte, Bab-O or Zud.	Rub with a dry cloth. Rub with a dry cloth or stainless steel wool. Apply with damp sponge or cloth. Rub with a damp cloth.	
Burnt-On Foods and Grease Fatty Acids, Milkstone (where swabbing or rubbing is not practical)	Easy-Off, De-Grease-It, 4 to 6% hot solution of such agents as trisodium phosphate or sodium tripolyphosphate or 5 to 15% caustic soda solution	Apply generous coating. Allow to stand for 10-15 minutes. Rinse. Repeated application may be necessary.	Excellent removal, satisfactory for use on all finishes.
Tenacious Deposits, Rusty Discolorations, Industrial Atmospheric Stains	Oakite No. 33, Dilac Texo 12, Texo NY, Flash-Klenz, Caddy Cleaner, Turco Scale 4368 or Permag 57.	Swab and soak with clean cloth. Let stand 15 minutes or more according to directions on package, then rinse and dry.	Satisfactory for use on all finishes
Hard Water Spots and Scale	Vinegar. 5% oxalic acid, 5% sulfamic acid, 5 to 10% phosphoric acid, or Dilac, Oakite No. 33, Texo 12, Texo N.Y.	Swab or wipe with cloth. Rinse with water and dry. Swab or soak with cloth. Let stand 10-15 minutes. Always follow with neutralizer rinse, and dry.	Satisfactory for all finishes. Satisfactory for all finishes. Effective on tenacious deposits or where scale has built up.

HELP

Trouble Diagnosis for the User		
Malfunction	Possible Cause	Likely Solution
No cooling - unit is silent	Unit not plugged in. Fuse or circuit breaker tripped. Power cord plug loose in outlet.	Connect to proper voltage circuit Replace fuse or reset breaker. Check outlet for loose connection, replace as needed
Unit cools but seems to be on all the time	Dirty condenser	Clean condenser
Space temperature too high	Dirty condenser Evaporator iced over Unit in high temperature environment	Clean condenser Defrost evaporator Reduce temperature of room
Space temperature too high, two system models	Same as above plus one compressor not operating	Call for service
Space temperature too low	Temperature control	Adjust or replace control
Trouble Diagnosis for the Technician		
No cooling - compressor does not hum	Temp control stuck in open position	Replace temp control.
No cooling - compressor hums but does not start	Low voltage to unit. Compressor starting system failure	Check voltage, correct as needed. Check start relay and start capacitor. See next step.
No cooling - compressor starts but shuts off	Compressor start relay failure Compressor start capacitor failure	Replace relay. Replace capacitor.
No cooling - compressor cycles on and off	Overheating weak overload	Clean condenser, check fan motor and blade. Check refrigerant charge. Replace overload.
Unit cools, but is slow to pull cabinet temperature down	Evaporator fan not turning	Check fan(s), on multiple fan units one fan may be turning slowly and will need to be replaced.
Unit cools but turns on and off frequently	No product in cabinet. Temperature control defective Refrigeration issue	Fill cabinet Replace control Have system checked
Makes excessive noise	Tubing rattle Loose parts Bent or broken fan blade Noisy fan motor	Check tubing for routing Check for loose components Replace fan blade Replace fan motor

FOR THE SERVICE TECH - R290

Refrigeration service should only be attempted by a trained trade professional certified to work on R290 systems.

Here are some critical service items.

This list does not qualify anyone to service the unit. It is a reminder and checklist for the service tech. Keep these in mind for **R290 service**:

- Wire nuts are **NOT** to be used when changing an electrical part.
- The switches in this product are sealed, **only exact replacements** may be used.
- The process tubes are to be used for service access.
- Cut out (with tubing cutter) refrigeration components that are to be replaced. Do **NOT** un-braze.
- Because R290 can be vented into the air during service, the venting **MUST** be in an area free from flame or spark. It must be near an opened window or door.
- A sign noting service of a system containing propane must be attached to the unit during refrigeration service.
- A combustible gas leak detector must be used to inform anyone in the area when propane is present in the air.

Other Information:

Evacuation: It is critical that a refrigeration system be leak free and internally dry. A thorough evacuation with a good vacuum pump with a micron gauge attached is the only way to ensure that the system is dry and ready for a charge of refrigerant.

Charging: The system is critically charged and the proper type and amount **MUST** be weighed in.

Overcharge symptoms: Unit will cool properly but the suction line temperature will be unusually cold. Compressor run time will be longer than normal.

Undercharge symptoms: Long run time, poor cooling and a hot compressor dome are the main symptoms of an undercharge.

FOR THE SERVICE TECH - SINGLE SYSTEM WIRING DIAGRAM

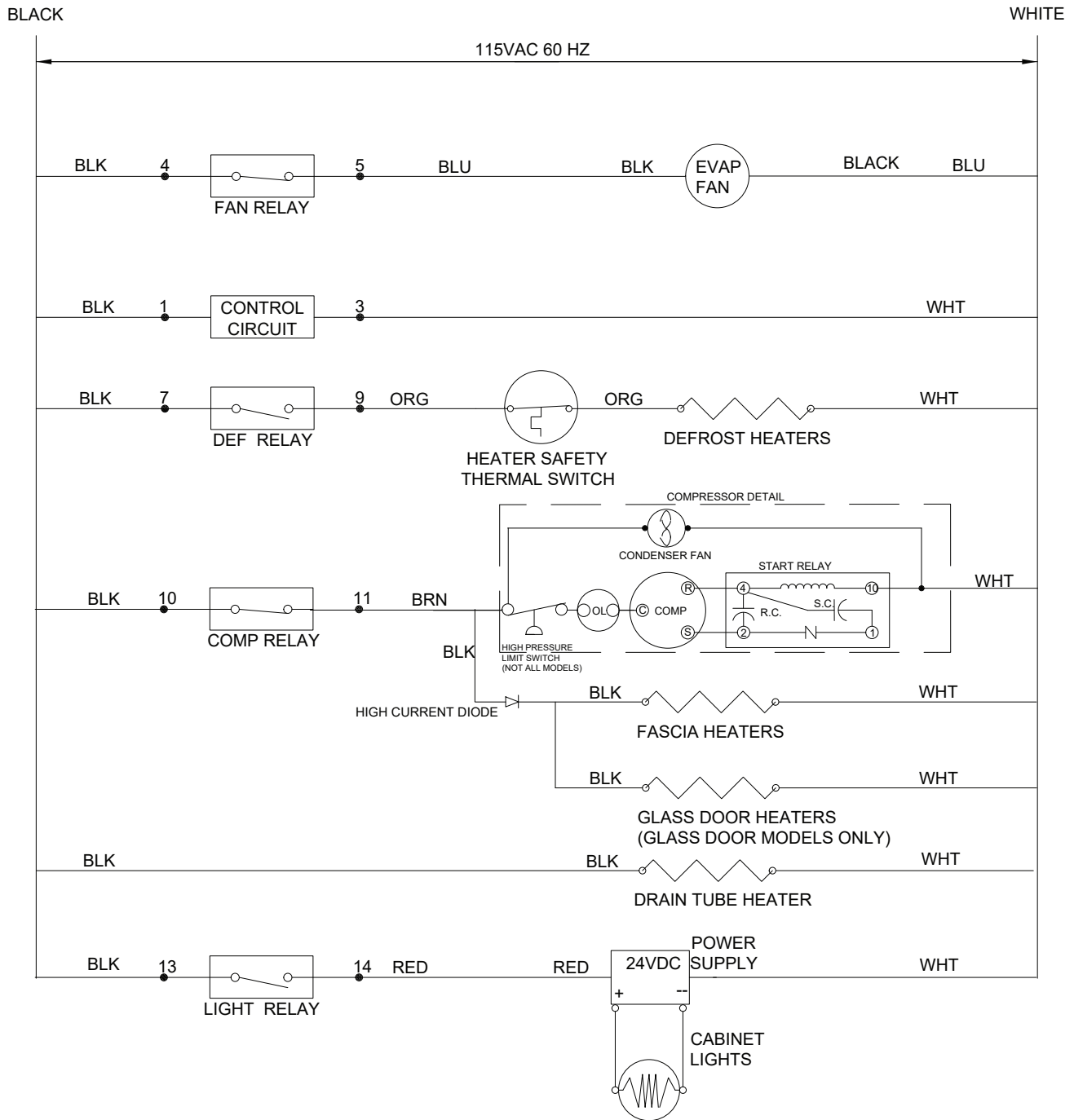

FOR THE SERVICE TECH - TWO SYSTEM WIRING DIAGRAM

115V FREEZER

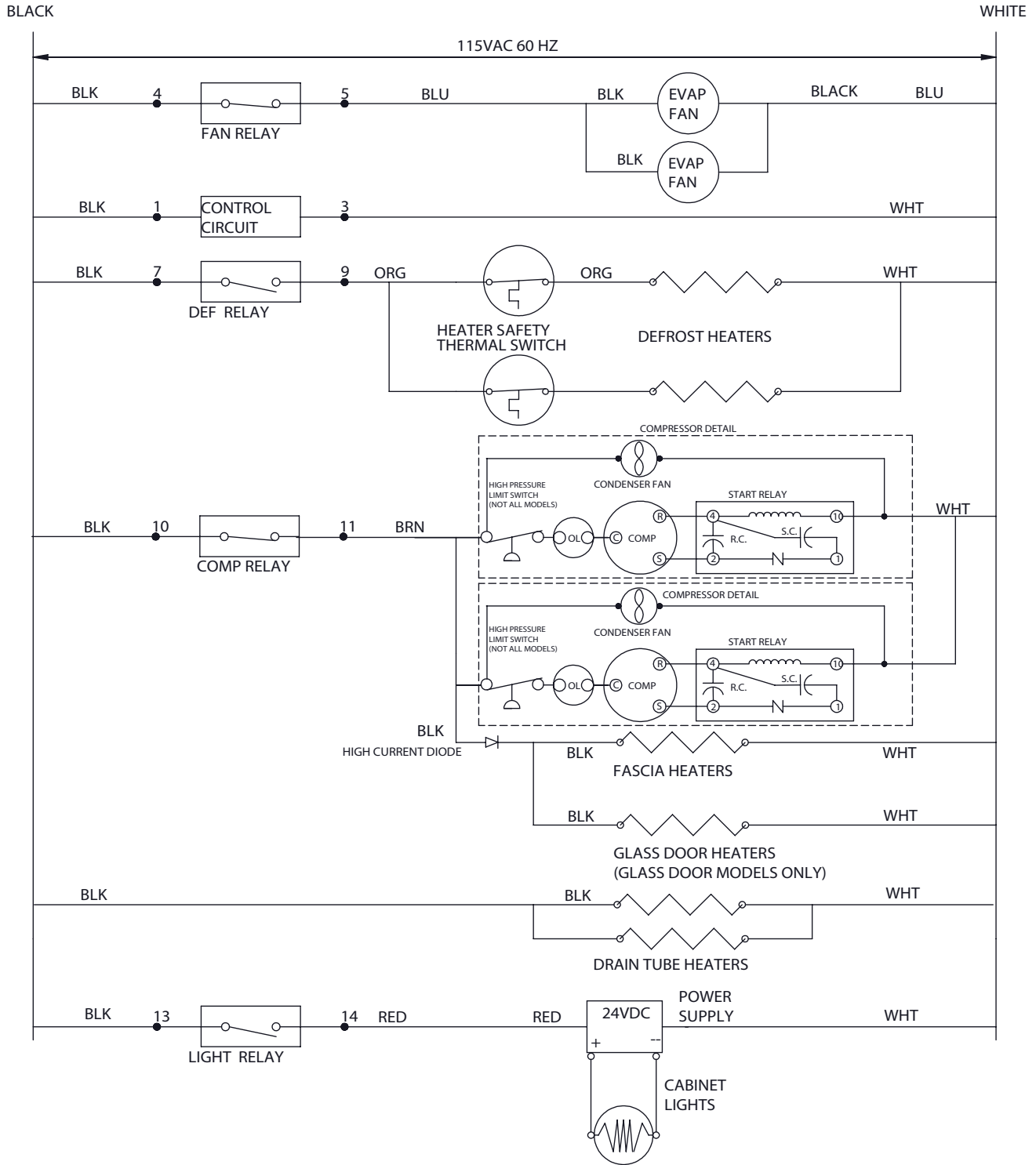

LIMITED WARRANTY

Warranty (Continental USA & Canada Only)

SEVEN (7) YEAR PARTS, LABOR, AND COMPRESSOR LIMITED WARRANTY

Victory® Refrigeration (Victory) warrants to the original purchaser of Victory branded equipment, that such equipment is free from defects in material and workmanship, under normal use, proper maintenance and service as indicated by Victory's installation and operation instructions, for a period of SEVEN (7) years from the date of installation, or eighty-seven (87) months from the date of shipment from the manufacturer, whichever is earlier. In addition, Victory® Refrigeration (Victory) warrants the hermetically/semi-hermetically sealed compressor (part only) for SEVEN (7) years; not to exceed eighty-seven (87) months from the date of shipment from Victory, provided upon receipt of the compressor, manufacturer examination shows the sealed compressor to be defective. This warranty does not cover freight for the replacement compressor or freight for return of the failed compressor. Also, this compressor-part only warranty does NOT apply to any electrical controls, condenser, evaporator, fan motors, overload switch, starting relay, capacitors, temperature control, filter/drier, accumulator, refrigeration tubing, wiring harness, labor charges, or supplies which are covered by the standard warranty above.

*Units shipped after 07/1/2024. Previous warranty applies to units shipped prior.

Exceptions:

- Warranty does not apply for units installed in a Residential application. Units are intended for Commercial use only.
- Blast Chillers carry a 3 year parts and labor warranty; 2 additional years for the compressor.

Normal wear type parts, such as light bulbs/lamps, gaskets, fuses, batteries, blast chiller/freeze probes, thermostat or electronic controller calibration and/or adjustment, and any normal maintenance items as outlined in the Owner's Manual, adjustment of door mechanisms or freight damage are not covered by this warranty. For this warranty, the original purchaser shall be deemed to mean the individual or company for whom the product was originally installed.

Proof of purchase must be supplied to Victory to validate the warranty. This warranty is valid only if equipment is properly installed, and started-up as outlined in the Owner's Manual.

Units that utilize variable speed compressor technology can experience nuisance tripping on Class A GFCI outlets which have a trip limit of 4 mA to 6 mA. To avoid this issue in a location that requires GFCI circuit protection, Beverage Air & Victory recommends using a HUBBELL Model Number GFRST83W 20A Heavy Duty Hospital Grade Self-Test GFCI Receptacle.

Removal or alteration of the serial/ data plate from equipment shall be deemed to release Victory from all warranty obligations or any other obligations, expressed or implied. The warranty does not cover installation, start-up, normal maintenance, food loss, or other consequential damage, and it excludes components that are removable without tools. Our obligation under this warranty shall be limited to repairing or replacing, including labor, any part of such product, which proves defective.

Victory reserves the right to examine any product claimed to be defective. The labor warranty shall be for self-contained units only and for standard straight time, which is defined as normal service rate time, for service performed during normal working hours. Any service requested outside of a servicer's normal working hours will be covered under this warranty at the normal rate and any additional overtime rate will be the responsibility of the equipment purchaser. Victory shall not be responsible for any costs incurred if the work is performed by other than Victory's authorized service personnel. Reimbursement claims for parts and/or labor service costs must be made in writing. Model, cabinet serial number and installation location must be shown on the claim. A receipted bill from the servicing agency must accompany the claim, together with full details of the service problems, diagnosis and work performed. Victory reserves sole discretion whether further documentation on a claim is to be submitted. Any part determined to be defective in the product should be returned to the company within thirty (30) days under the terms of this warranty and must be accompanied by a record of the cabinet model, serial number, with a return material authorization number (RMA#) issued by Victory.

LIMITED WARRANTY (CONTINUED)

Special installation/applications, including remote locations, are limited in coverage by this warranty. Any installation that requires extra work, and/or travel, to gain access to the unit for service is the sole responsibility of the equipment purchaser. Improper operation resulting from factors, including but not limited to, improper or negligent cleaning and maintenance, low voltage conditions, inadequate wiring, outdoor use and accidental damage are not manufacturing defects and are strictly the responsibility of the purchaser.

Except Blast Chillers, a product is designed for maintaining temperature and not bringing food to a desired temperature, so cannot be held responsible for this function under warranty.

Units must be in conditioned environments or warranty will be void.

Condenser coils must be cleaned at regular intervals. Failure to do so can cause compressor malfunction and will void warranty. Although cleaning requirements vary in accordance with the operation of various products, Victory recommends a minimum monthly cleaning.

NOTE: NO CLAIMS CAN BE MADE AGAINST THESE WARRANTIES FOR SPOILAGE OF PRODUCTS, LOSS OF SALES OR CONSEQUENTIAL DAMAGES. THE FOREGOING WARRANTIES ARE EXPRESSLY GIVEN IN LIEU OF ALL OTHER WARRANTIES, EXPRESS, IMPLIED, OR STATUTORY, INCLUDING THE IMPLIED WARRANTIES OF MERCHANTABILITY AND FITNESS FOR A PARTICULAR PURPOSE, WHICH ARE HEREBY DISCLAIMED, AND ALL OTHER OBLIGATIONS OR LIABILITIES ON OUR PART, AND WE NEITHER ASSUME, NOR AUTHORIZE ANY OTHER PERSON TO ASSUME FOR US, ANY OBLIGATION OR LIABILITY IN CONNECTION WITH THE SALE OF SAID REFRIGERATION UNITS OR ANY PARTS THEREOF.

These warranties shall not be assignable and shall be honored only in so far as the original purchaser.

These warranties do not apply outside the limits of the USA and Canada, nor do they apply to any part that has been subject to misuse, neglect, alteration, accident, or to any damage caused by transportation, flood, fire, acts of terrorism, or acts of God.

LIMITATION OF LIABILITY:

Victory or its affiliates shall not be liable for any indirect, incidental, special or consequential damages, or losses of a commercial nature arising out of malfunctioning equipment or its parts or components thereof, because of defects in material or workmanship. In no event shall Victory be liable for a sum more than the purchase price of the item.

THE ORIGINAL OWNER'S SOLE AND EXCLUSIVE REMEDY AND VICTORY'S SOLE AND EXCLUSIVE LIABILITY SHALL BE LIMITED TO THE REPAIR OR REPLACEMENT OF PARTS OR COMPONENTS CONTAINED IN THE EQUIPMENT IDENTIFIED ABOVE WHICH UNDER NORMAL USE AND SERVICE MALFUNCTION AS A RESULT OF DEFECTS IN MATERIAL OR WORKMANSHIP, SUBJECT TO THE APPLICABLE PROVISIONS AND LIMITATIONS STATED ABOVE.

07/2024

Warranty Registration

Register your product online at Victory.com/parts-service or fill out and mail the form below.

Cabinet Model Number: _____ Date Of Installation: _____

Cabinet Serial Number: _____

Location Of Product

Business Name: _____

Business Street: _____

Business City: _____ State: _____ Postal Code: _____

Mail to: Victory, 3779 Champion Blvd, Winston-Salem, NC 27105

Rev. 02/26

